



Unit measures 2.76"W x 3.94"L x 0.75"H

- Wide 2 : 1 Input Range
- High Efficiency
- Regulated Outputs
- 1600V Isolation
- Full EMI Shielding
- PI Input Filter

Model Number	Output Voltage	Output Amps	Input Range
SINGLE OUTPUT			
FDC40-12S33	3.3 VDC	10	9-18 VDC
FDC40-24S33		10	18-36 VDC
FDC40-48S33		10	36-72 VDC
FDC40-12S05	5 VDC	8	9-18 VDC
FDC40-24S05		8	18-36 VDC
FDC40-48S05		8	36-72 VDC
FDC40-12S12	12 VDC	3.4	9-18 VDC
FDC40-24S12		3.4	18-36 VDC
FDC40-48S12		3.4	36-72 VDC
FDC40-12S15	15 VDC	2.7	9-18 VDC
FDC40-24S15		2.7	18-36 VDC
FDC40-48S15		2.7	36-72 VDC



UL E193009;
TUV R2054535;
CB JPTUV-001393





Unit measures 2.76"W x 3.94"L x 0.75"H

- Wide 2 : 1 Input Range
- High Efficiency
- Regulated Outputs
- 1600V Isolation
- Full EMI Shielding
- PI Input Filter



UL E193009;
TUV R2054535;
CB JPTUV-001393

Model Number	Output Voltage	Output Amps	Input Range
DUAL OUTPUT			
FDC40-12D3305	3.3 / 5 VDC	4-Apr	9-18 VDC
FDC40-24D3305		4-Apr	18-36 VDC
FDC40-48D3305		4-Apr	36-72 VDC
FDC40-12D05	+/-5 VDC	-7	9-18 VDC
FDC40-24D05		-7	18-36 VDC
FDC40-48D05		-7	36-72 VDC
FDC40-12D12	+/-12 VDC	+/-1.8	9-18 VDC
FDC40-24D12		+/-1.8	18-36 VDC
FDC40-48D12		+/-1.8	36-72 VDC
FDC40-12D15	+/-15 VDC	+/-1.4	9-18 VDC
FDC40-24D15		+/-1.4	18-36 VDC
FDC40-48D15		+/-1.4	36-72 VDC
TRIPLE OUTPUT			
FDC40-12T0512	5, +/-12 VDC	4, +/-0.85	9-18 VDC
FDC40-24T0512		4, +/-0.85	18-36 VDC
FDC40-48T0512		4, +/-0.85	36-72 VDC
FDC40-12T0515	5, +/-15 VDC	4, +/-0.68	9-18 VDC
FDC40-24T0515		4, +/-0.68	18-36 VDC
FDC40-48T0515		4, +/-0.68	36-72 VDC



INPUT SPECIFICATIONS

Input Voltage Ranges:	12 VDC Nominal	9-18 VDC
	24 VDC Nominal	18-36 VDC
	48 VDC Nominal	36-72 VDC
Input Filter	Pi Type	

OUTPUT SPECIFICATIONS

Voltage and Current	See Selection Chart	
Load Regulation	singles: +/-0.5%	
	duals: +/-1%	
	triples: 5 V: +/-2%, Aux: +/-5%	
Line Regulation	singles: +/-0.5%	
	duals: +/-1%	
	triples: 5V: +/-2%, Aux: +/-5%	
Temperature Coefficient	+/-0.02%/DegC	
Ripple/Noise	1% Pk-Pk of Vout, typ	
Voltage Stability	(singles/duals)	+/- 2%
	(triples)	5 V: +/-2%, Aux: +/-5%
Short Circuit Protection	Continuous, self-recovering	
Overvoltage Protection Threshold:	3.3V Output	3.9Volts
	5V Output	6.2Volts
	12V Output	15Volts
	15V Output	18Volts

GENERAL SPECIFICATIONS

On/Off Control	(Ref to - Input pin)
	Logic "1"/Open=ON
	Logic "0"/GND=OFF
Input-Out Isolation	1600VDC
Isolation Resistance	10000 M Ohms
Efficiency	82%, typ
Switching Frequency	185Khz, typ

ENVIRONMENTAL SPECIFICATIONS

Oper. Temperature (Case)	-25 to +85 DegC(see derate)
Storage Temperature	-55 to +125 DegC *
Maximum Case Temp	100 DegC *
MTBF	1.61 MHours
	MIL-HDBK-217F TA=25C FL

PHYSICAL SPECIFICATIONS

Case Material	Nickel-Coated Copper
	Non-Conductive Base
Construction	Fully Encapsulated
Weight	4.5 oz, (126g)

EFFICIENCY CURVES

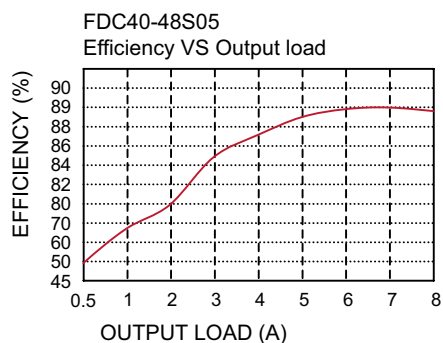
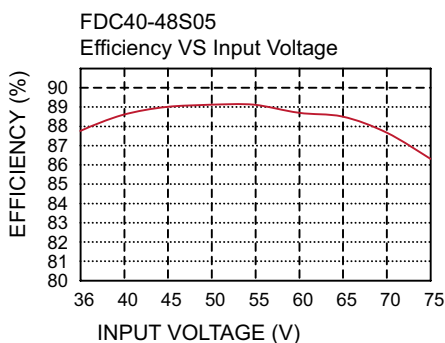

All specifications are typical at nominal input, full load, and 25DegC unless otherwise noted

* These are stress ratings. Exposure of the devices to any of these conditions may adversely affect long term reliability. Proper operation under conditions other than the standard operating conditions is neither warranted nor implied.

Astrodyne products are not authorized or warranted for use as critical components in life support systems, equipment used in hazardous environments, nuclear controls systems, or other mission-critical applications.

MECHANICAL DIMENSIONS

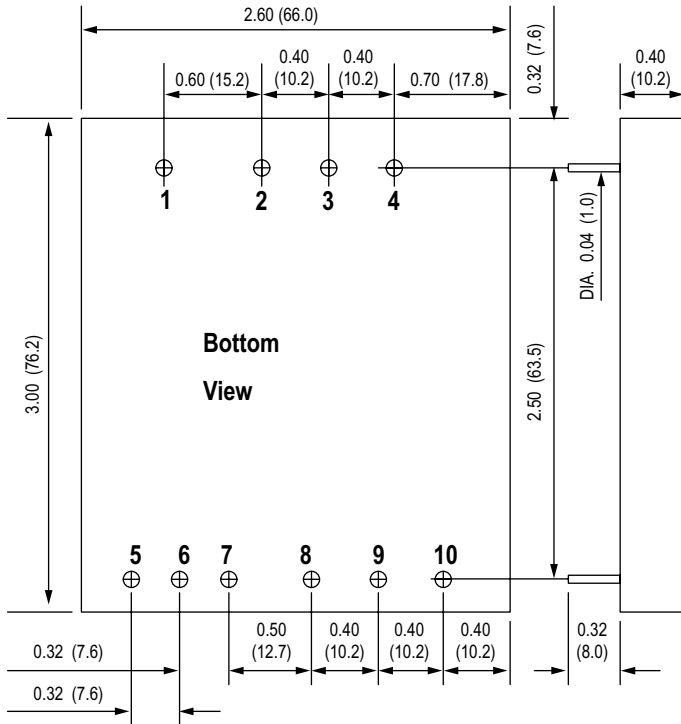

1. All dimensions in Inches (mm)
2. Pin pitch tolerance 0.014 (0.35)

EXTERNAL OUTPUT TRIMMING

Output can be externally trimmed by using the method shown below.
 () for dual output trim
 [] for triple output trim
 { } XXD3305 only trim 3.3V/5V

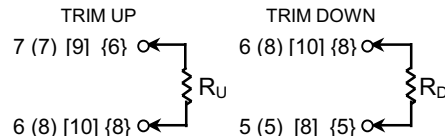

Pin #	Single	Dual	Triple
1	Ctrl	Ctrl	Ctrl
2	+ Vin	+ Vin	+ Vin
3	- Vin	- Vin	- Vin
4	Sync	Sync	Sync
5	+ OutS	+ Vout or 3.3 out	+ Vout
6	Trim	Com	Com
7	- OutS	- Vout or 5 out	- Vout
8	+ Vout	Trim	+5 Out
9	- Vout	No Pin	-5 Out
10	No Pin	No Pin	Trim

OUTPUT DERATING CURVE

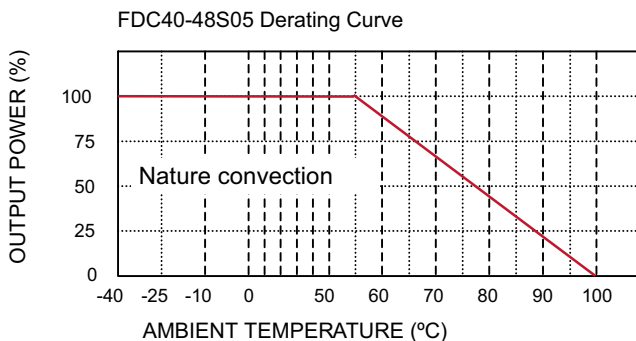

APPLICATION OF SYNCHRONIZATION

1. The unit is capable of external synchronization from an independent time base with a switching rate between 200kHz and 215kHz
2. The amplitude of the synchronizing pulse train is TTL compatible
3. The duty cycle of the CLK should be 20% high and 80% low
4. Synchronization is referenced to negative input (-Vin)

